



TFT MODULE SPECIFICATION

## **RVT50HQTNWC00 V2.0A**

IPS RGB 5.0” display datasheet  
Rev. 1.1  
2026-06-30

---

**Riverdi Sp. z o.o.**

Nowy Swiat 36  
80-299 Gdansk, Poland  
VAT ID: PL5842767153  
Registration number (KRS): 0000923967

**+48 587 703 116**

Office hours: 9:00 to 17:30 CET (Mon-Fri)

**[contact@riverdi.com](mailto:contact@riverdi.com)**

**[riverdi.com](http://riverdi.com)**



ITEM	CONTENTS	UNIT
LCD Type	TFT/Transmissive/Normally black/IPS	/
Size	5.0	Inch
Viewing Direction	Free	/
Outside Dimensions (W x H x D)	136.00 x 92.80 x 5.65	mm
Active Area (W x H)	108.00 x 64.80	mm
Pixel Pitch (W x H)	0.135 x 0.135	mm
Resolution	800 x 480 (RGB)	/
Brightness	800	cd/m <sup>2</sup>
LCD Interface Type	RGB	/
Color Depth	16.7 M	/
Pixel Arrangement	RGB Vertical Stripe	/
LCD Driver	ST7262-G4	/
With/Without Touch	With Capacitive Touch Panel	/
CTP IC	ILI2132A	/
LCD Input Voltage	3.3	V
Weight	TBD	g

**Note 1.** RoHS3 compliant

**Note 2.** LCM weight tolerance:  $\pm 5\%$ .

## 1. REVISION RECORD

REV NO.	REV DATE	CONTENTS	REMARKS
1.0	2026-05-15	Initial release	
1.1	2026-06-30	Updated drawing with EMI shielding on FPC.	

## 2. CONTENTS

1.	REVISION RECORD .....	3
2.	CONTENTS .....	4
3.	MODULE CLASSIFICATION INFORMATION .....	5
4.	ASSEMBLY .....	6
4.1	uxTouch Assembly .....	6
5.	MODULE DRAWING .....	7
6.	ABSOLUTE MAXIMUM RATINGS .....	8
7.	ELECTRICAL CHARACTERISTICS .....	8
8.	Touch panel CHARACTERISTICS .....	9
9.	BACKLIGHT ELECTRICAL CHARACTERISTICS .....	9
10.	ELECTRO-OPTICAL CHARACTERISTICS .....	10
11.	INTERFACES DESCRIPTION .....	13
11.1	TFT ASSIGNMENT .....	13
11.2	Touch Panel Connector .....	14
11.3	CN1 assignment .....	14
12.	TIMING CHART .....	15
12.1	Timing characteristics .....	15
12.2	System bus timing for RGB interface .....	16
12.3	DC Electrical Characteristics .....	17
13.	INSPECTION .....	17
14.	RELIABILITY TEST .....	18
15.	LEGAL INFORMATION .....	20
16.	CONTACT .....	21

### 3. MODULE CLASSIFICATION INFORMATION

RV	T	50	H	Q	T	N	W	C	00	V2.0A
1.	2.	3.	4.	5.	6.	7.	8.	9.	10.	11.

NO.	PARAMETER	SYMBOL
1.	BRAND	RV - Riverdi
2.	PRODUCT TYPE	T - TFT Standard
3.	DISPLAY SIZE	50 - 5.0"
4.	MODEL SERIAL NO.	H - High Brightness, IPS
5.	RESOLUTION	Q - 800 x 480 px
6.	INTERFACE	T - TFT LCD, RGB
7.	FRAME	N - Without Mounting Metal Frame
8.	BACKLIGHT TYPE	W - LED White
9.	TOUCH PANEL	C - With Capacitive Touch Panel
10.	VERSION	00 - uxTouch
11	MODULE REVISION	V2.0A

## 4. ASSEMBLY

### 4.1 uxTouch Assembly

uxTouch are LCD TFT displays with specially designed projected capacitive touch panels. uxTouch display can be mounted without any additional holes in the housing. Our standard uxTouch displays include double-sided adhesive tape (DST) to stick TFT easily to the housing.

uxTouch models with double-side adhesive tape can be mounted by fastening the glass to the housing.

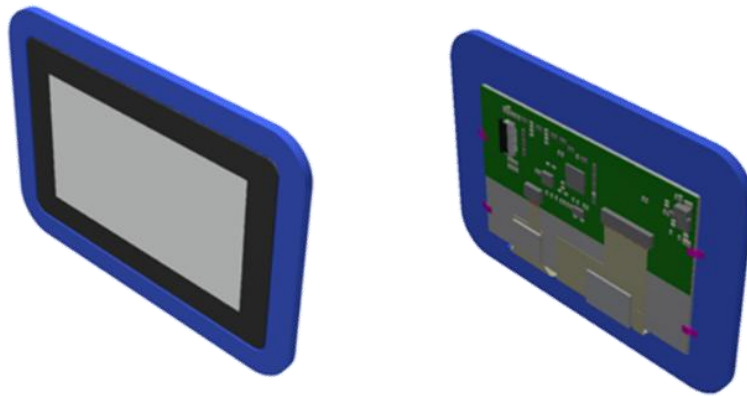

*Figure 1. General view of the module*

Revision:	Changes:	Date:
1.0	Initial Case	2026.03.19
1.1	Added EMI Shielding on FPC	2026.06.30

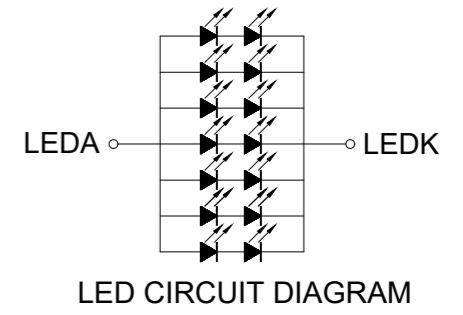
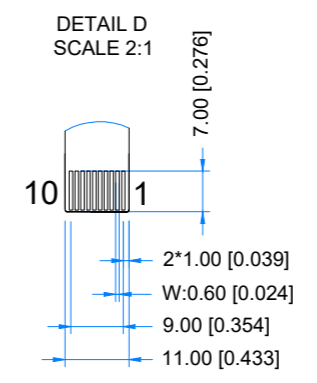
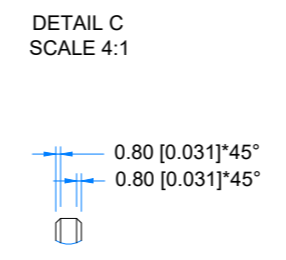
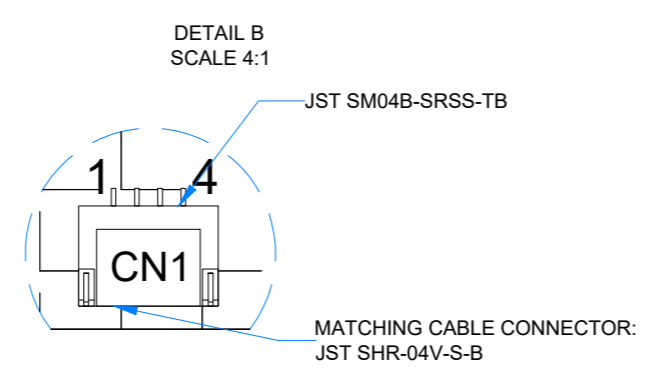
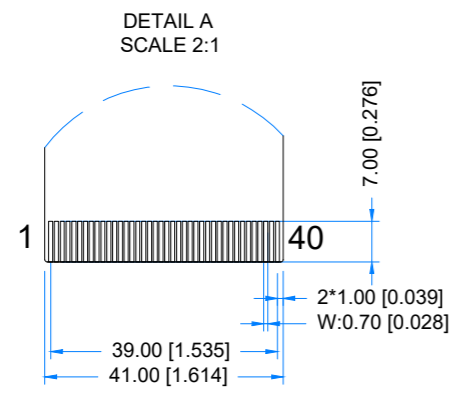
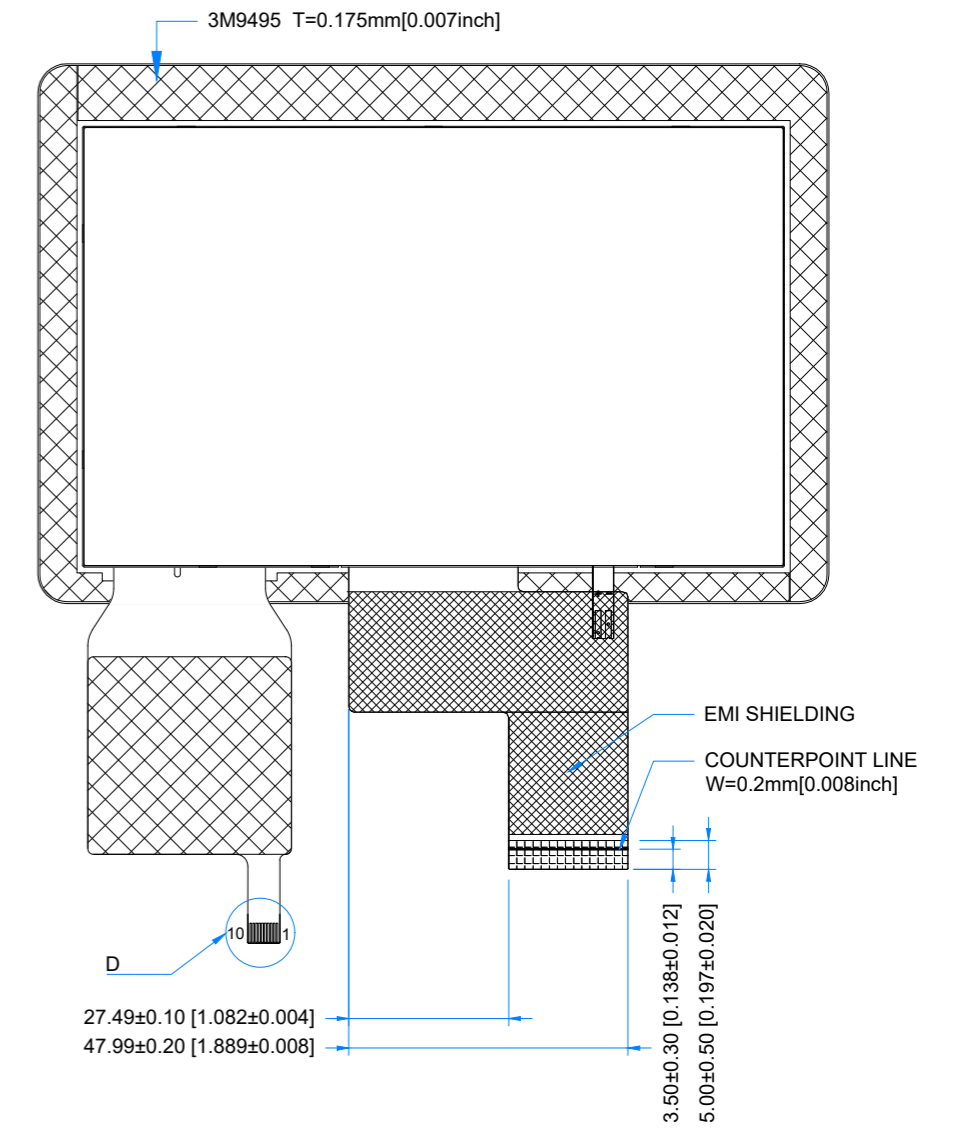
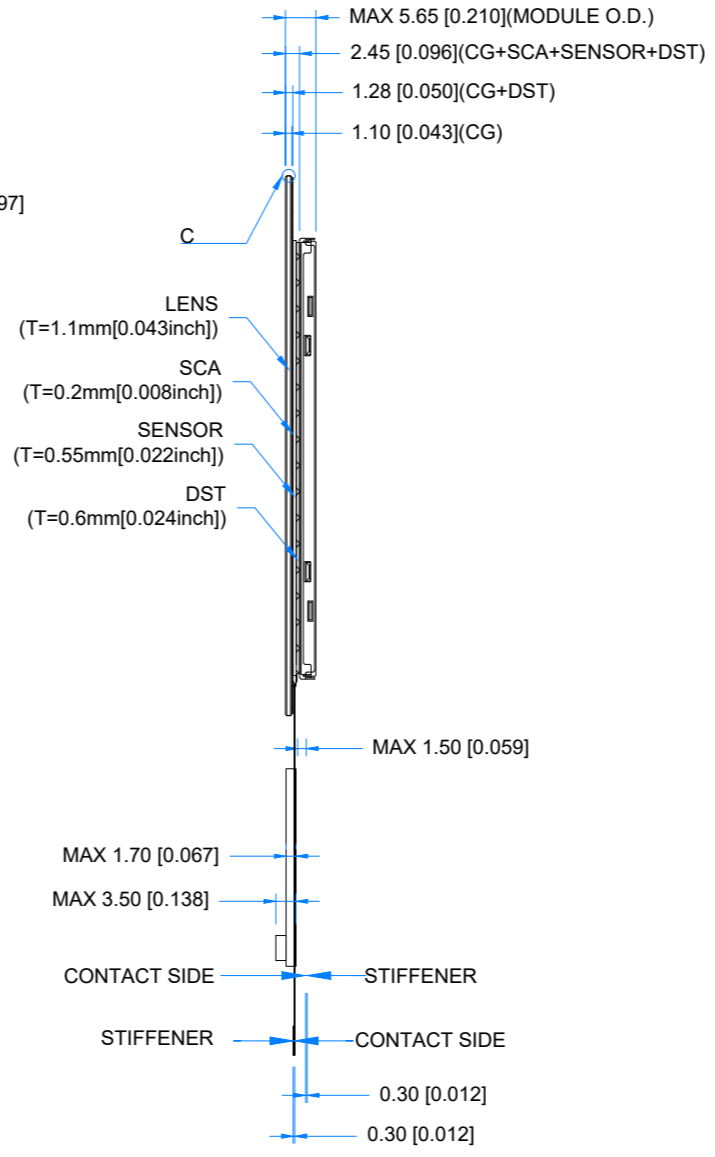
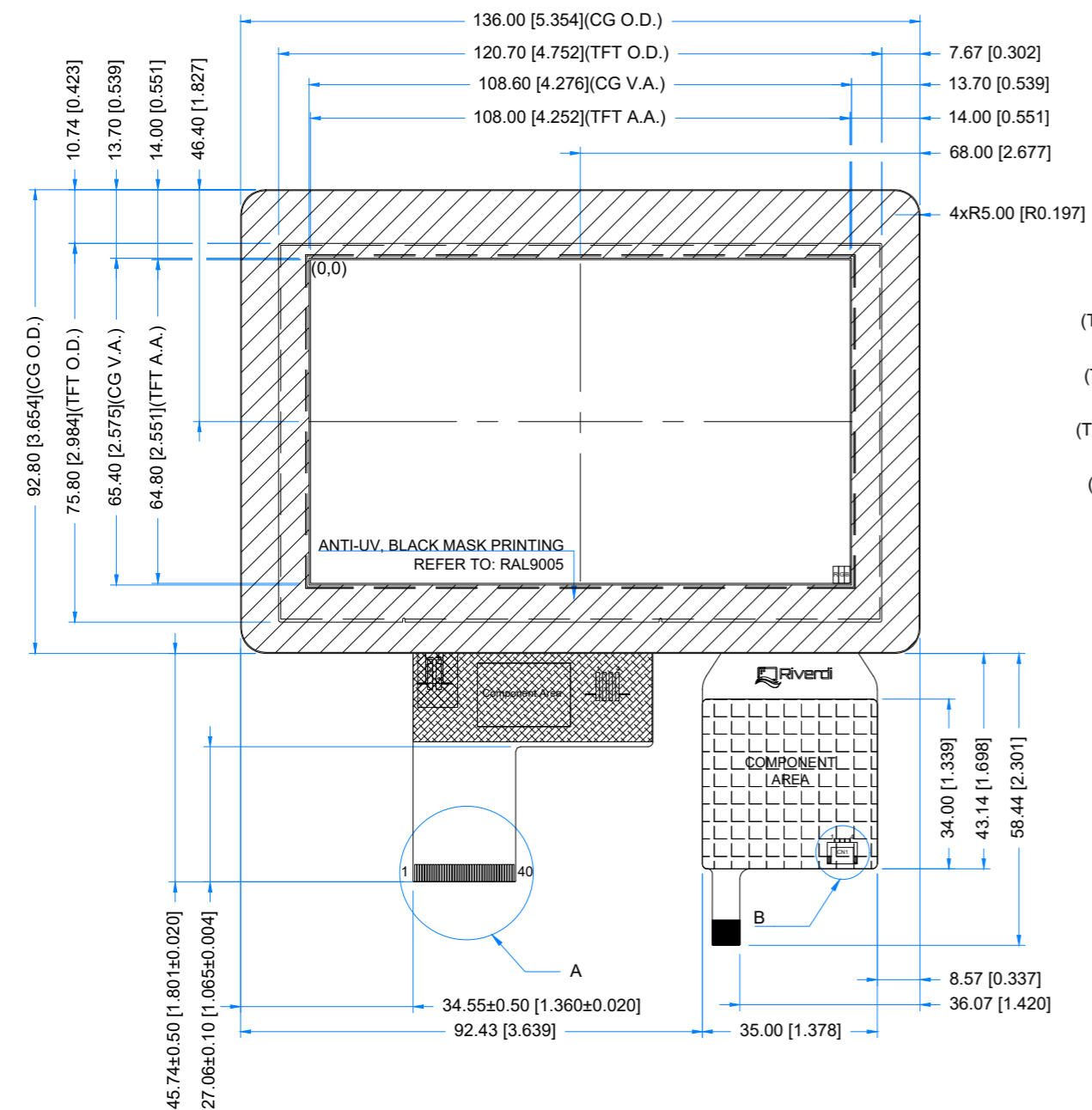

**TFT NOTES:**  
1. DISPLAY TYPE: TRANSMISSIVE, NORMALLY BLACK, IPS  
2. RESOLUTION: 800x480  
3. VIEWING ANGLE: FREE  
4. INTERFACE: RGB  
5. IC CONTROLLER: ST7262-G4  
6. OPERATING VOLTAGE: 3.3V  
7. BACKLIGHT: 14-LED WHITE, Vf=12.0V, If=140mA

**TP NOTES:**  
1. TP STRUCTURE: G+G  
2. CG THICKNESS: 1.1mm[0.043inch]  
3. DRIVER IC: ILI2132A  
4. INTERFACE: USB; I2C  
5. OPERATING VOLTAGE: 3.3V(I2C); 5.0V(USB)

**GENERAL NOTES:**  
1. SURFACE LUMINANCE: 800cd/m<sup>2</sup>  
2. OPERATING TEMPERATURE: -20°C ~ 70°C  
3. STORAGE TEMPERATURE: -30°C ~ 80°C  
4. WITHOUT INDIVIDUAL TOLERANCE: ±0.3mm  
5. RoHS COMPLIANT

PN: RVT50HQTNWC00 V2.0A  
SN:  
DRAWN: M.Stabinski 2026.06.30 1:1.30  
CHECKED: M.Wierzbowski 2026.06.30 [mm]  
APPR: M.Wierzbowski 2026.06.30 ISO A3



## 6. ABSOLUTE MAXIMUM RATINGS

PARAMETER	SYMBOL	MIN	MAX	UNIT
Analog supply voltage	$V_{CI}$	-0.3	+4.0	V
Backlight Forward Current	$I_F$	-	140	mA
Operating Temperature	$T_{OP}$	-20	70	°C
Storage Temperature	$T_{ST}$	-30	80	°C

**Note.** The above are maximum values. If exceeded, they may cause permanent damage to the unit.

## 7. ELECTRICAL CHARACTERISTICS

PARAMETER	SYMBOL	MIN	TYP	MAX	UNIT	REMARK
Digital supply voltage	$V_{DDI}$	3.1	3.3	3.6	V	-
Input Signal Voltage	Low Level $V_{IL}$	0	-	$0.3V_{DD}$	V	RXIN0- ,RXIN0+,RXI N1- ,RXIN1+,RXI N2- ,RXIN2+SELB ,RESET,STBY B,L/R,U/D
	High Level $V_{IH}$	$0.7V_{DD}$	-	$V_{DD}$	V	
Touch Panel Supply Current	$I_{CTP}$	-	107	-	mA	Measured average current, touch panel active

## 8. TOUCH PANEL CHARACTERISTICS

PARAMETER	SYMBOL	VALUE	REMARK
Touch panel interface	-	I <sup>2</sup> C	
I <sup>2</sup> C 7-bit slave address	ADDR <sub>7-bit</sub>	0x41	Standard I <sup>2</sup> C address format
I <sup>2</sup> C write address	ADDR <sub>w</sub>	0x82	8-bit address format
I <sup>2</sup> C read address	ADDR <sub>r</sub>	0x83	8-bit address format

## 9. BACKLIGHT ELECTRICAL CHARACTERISTICS

PARAMETER	SYMBOL	MIN	TYP	MAX	UNIT	NOTE
Backlight Driving Voltage	V <sub>F</sub>	11.2	12.0	12.8	V	Notes 1, 2
Backlight Driving Current	I <sub>F</sub>	-	140	-	mA	
Backlight Power Consumption	W <sub>BL</sub>	-	1680	-	mW	
Backlight Lifetime	-	-	50,000	-	hours	Note 3

**Note 1.** Unless specified, the ambient temperature  $T_a = 25^\circ\text{C}$

**Note 2.** The recommended operating conditions refer to a range in which operation of this product is guaranteed. Should this range be exceeded, the operation cannot be guaranteed even if the values may be without the absolute maximum ratings.

**Note 3.** If LED is driven by high current, the lifetime of LED will be reduced. Operating life means brightness goes down to 50% initial brightness. Typical operating lifetime is estimated data.

## 10. ELECTRO-OPTICAL CHARACTERISTICS

ITEM	SYMBOL	CONDITION	MIN	TYP	MAX	UNIT	RMK	NOTE
Response Time	Tr+Tf	$\theta=0^\circ$ $\phi=0^\circ$ Ta=25 °C	-	30	40	ms	FIG 2.	4, 7
Contrast Ratio	Cr		800	1000	-	---	FIG 3.	1, 7
Surface Luminance	Lv		-	800	-	cd/m <sup>2</sup>		2, 7
Uniformity	U	-	75	80	-	%	FIG 3.	3
Viewing Angle Range	$\theta$	$\phi = 90^\circ$	70	80	-	deg	FIG 4.	6
		$\phi = 270^\circ$	70	80	-	deg		
		$\phi = 0^\circ$	70	80	-	deg		
		$\phi = 180^\circ$	70	80	-	deg		
CIE (x, y) Chromaticity	Rx	$\theta=0^\circ$ $\phi=0^\circ$ Ta=25 °C	-0.03	0.315	+0.03	-	FIG 3.	5,7
	Ry			0.341		-		
	Gx			0.584		-		
	Gy			0.350		-		
	Bx			0.365		-		
	By			0.572		-		
	Wx			0.155		-		
	Wy			0.115		-		

**Note 1.** Contrast Ratio (CR) is defined mathematically as below, for more information see Figure 2.

$$\text{Contrast Ratio} = \frac{\text{Average Surface Luminance with all white pixels (P1, P2, P3, P4, P5)}}{\text{Average Surface Luminance with all black pixels (P1, P2, P3, P4, P5)}}$$

**Note 2.** Surface luminance is the LCD surface from the surface with all pixels displaying white. For more information see Figure 2.

$$L_v = \text{Average Surface Luminance with all white pixels (P1, P2, P3, P4, P5)}$$

**Note 3.** The uniformity in surface luminance  $\delta$  WHITE is determined by measuring luminance at each test position 1 through 5, and then dividing the minimum luminance of 5 points luminance by maximum luminance of 5 points luminance. For more information see Figure 2.

$$\delta \text{ WHITE} = \frac{\text{Minimum Surface Luminance with all white pixels (P1, P2, P3, P4, P5)}}{\text{Maximum Surface Luminance with all white pixels (P1, P2, P3, P4, P5)}}$$

**Note 4.** Response time is the time required for the display to transition from white to black (Rise Time,  $T_r$ ) and from black to white (Decay Time,  $T_f$ ). For additional information see Figure 1. The test equipment is BM-7A.

**Note 5.** CIE (x, y) chromaticity, the x, y value is determined by measuring luminance at each test position 1 through 5, and then make average value.

**Note 6.** For TFT module, viewing angle is the angle at which the contrast ratio is greater 10. The angles are determined for the horizontal or x axis and the vertical or y axis with respect to the z axis which is normal to LCD surface. For more information see Figure 3.

**Note 7.** Viewing angle is measured at the center point of the LCD by CONOSCOPE (ergo-80). For response time testing, the testing data is based on BM-7A. Instruments for Contrast Ratio, Surface Luminance, Luminance Uniformity, Chromaticity the test data is based on SR-3A.

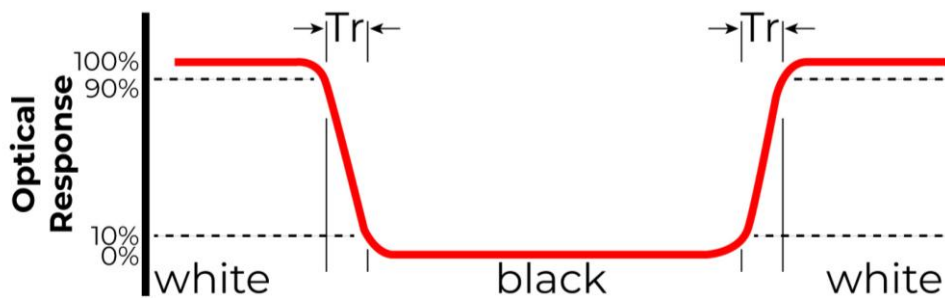

Figure 2. The definition of response time

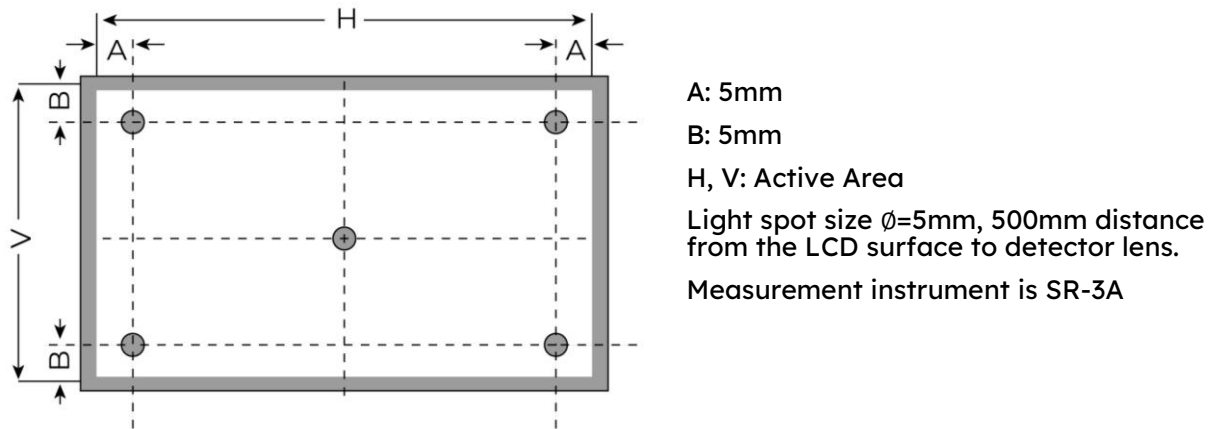

Figure 3. Measuring method for Contrast ratio, surface luminance, Luminance uniformity, CIE (x, y) chromaticity

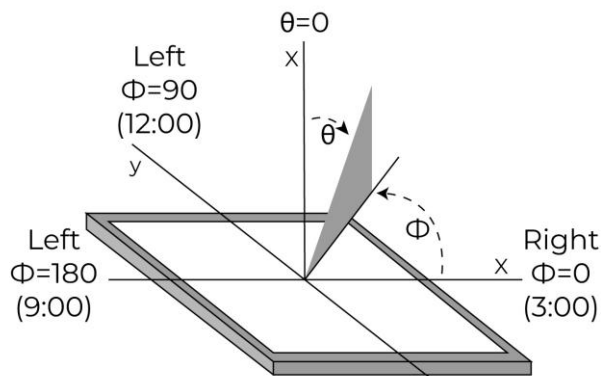

Figure 4. The definition of viewing angle

## 11. INTERFACES DESCRIPTION

### 11.1 TFT ASSIGNMENT

PIN	SYMBOL	DESCRIPTION
<b>1</b>	LEDK	Power supply for LED
<b>2</b>	LEDA	Power supply for LED
<b>3</b>	GND	Ground
<b>4</b>	VDD	Power Supply Voltage
<b>5-12</b>	DR0-DR7	Red Data
<b>13-20</b>	DG0-DG7	Green Data
<b>21-28</b>	DB0-DB7	Blue Data
<b>29</b>	GND	Ground
<b>30</b>	PCLK	Pixel Clock signal in RGB interface
<b>31</b>	DISP	Display on/off Control
<b>32</b>	HSYNC	Horizontal sync signal in RGB interface
<b>33</b>	VSNC	Vertical sync signal in RGB interface
<b>34</b>	DE	Data Enable signal in RGB interface
<b>35</b>	NC	No connection
<b>36</b>	GND	Ground
<b>37</b>	NC	No Connection
<b>38</b>	NC	No Connection
<b>39</b>	NC	No Connection
<b>40</b>	NC	No Connection

## 11.2 Touch Panel Connector

PIN	SYMBOL	DESCRIPTION
1	USB_GND	USB Ground
2	USB_VDD	USB Power for CTP, 5.0V
3	USB_D-	USB Data signal-
4	USB_D+	USB Data signal+
5	I2C_GND	I2C Ground
6	I2C_VDD	I2C Power for CTP 3.3V
7	I2C_RST	I2C Reset pin, active low
8	I2C_SCL	I2C Clock input
9	I2C_INT	I2C Interrupt signal from CTP, active low
10	I2C_SDA	I2C Data signal

## 11.3 CN1 assignment

PIN	SYMBOL	DESCRIPTION
1	USB_VDD	USB_Power for CTP, DC 5.0V
2	USB_D-	USB_Data signal -
3	USB_D+	USB_Data signal +
4	USB_GND	USB_Ground

## 12. TIMING CHART

### 12.1 Timing characteristics

PARAMETER	SYMBOL	MIN	TYP	MAX	UNIT	CONDITIONS
CLK Pulse Duty	Tclk	40	50	60	%	
VSYNC Setup Time	Tvst	10	-	-	ns	
VSYNC Hold Time	Tvhd	10	-	-	ns	
HSYNC Setup Time	Thst	10	-	-	ns	
HSYNC Hold Time	Thhd	10	-	-	ns	
Data Setup Time	Tdsu	10	-	-	ns	
Data Hold Time	Tdhd	10	-	-	ns	
DE Setup Time	Tdest	10	-	-	ns	
DE Hold Time	Tdehd	10	-	-	ns	

## 12.2 System bus timing for RGB interface

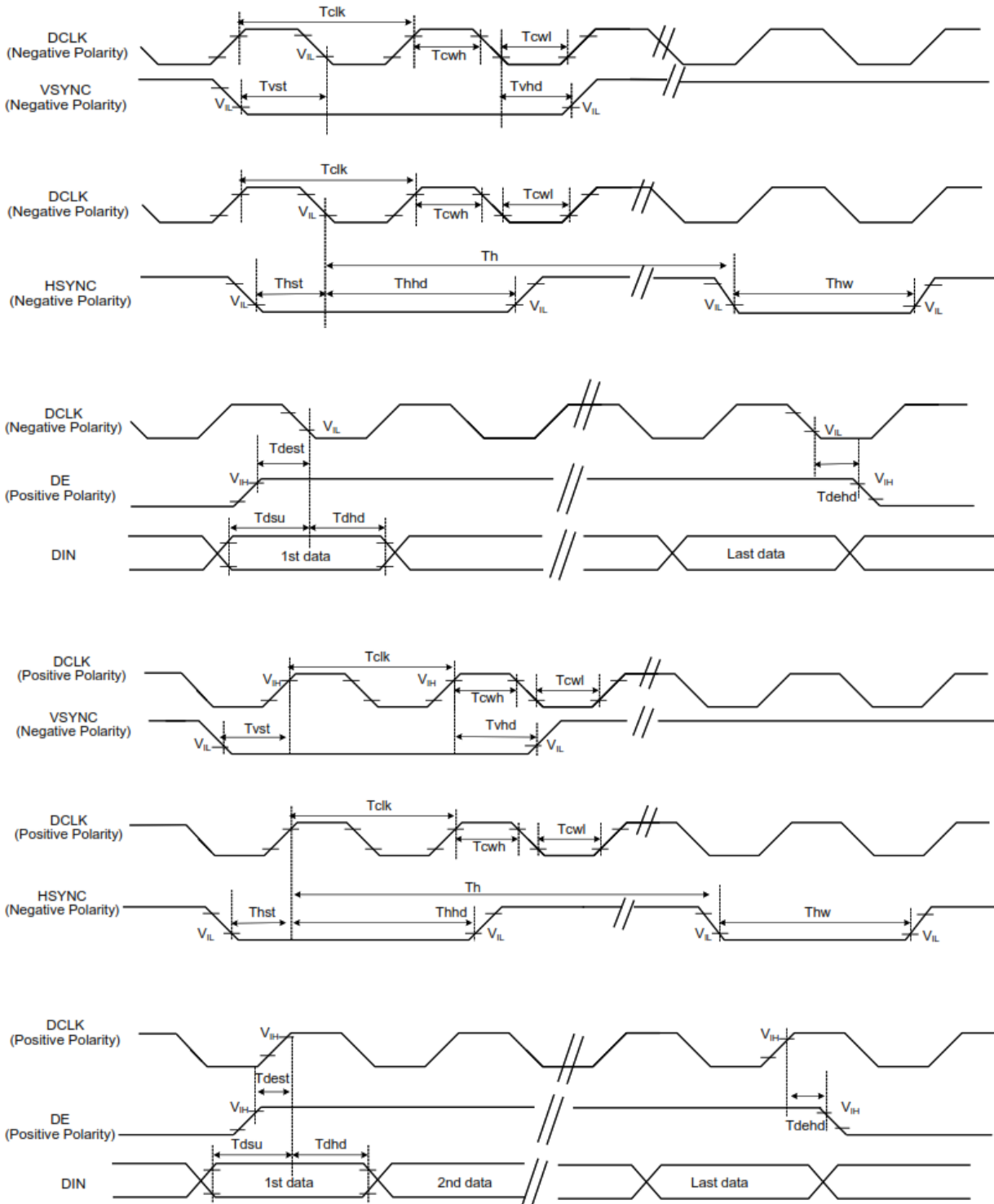

## 12.3 DC Electrical Characteristics

PARAMETER	SYMBOL	MIN	TYP	MAX	UNIT	REMARK
Analog Supply Voltage	VCI	3.1	3.3	3.6	V	-
<b>Input High Voltage</b>	VIH	0.7VDDI	-	VDDI	V	Digital input pins
<b>Input Low Voltage</b>	VIL	DGND	-	0.3VDDI	V	Digital input pins
<b>Output High Voltage</b>	VOH	VDDI-0.4	-	VDDI	V	Digital input pins
<b>Output Low Voltage</b>	VOL	DGND	-	DGND+0.4	V	Digital input pins
<b>Power consumption (Panel+LSI)</b>	Black Mode	-	50	-	mA	VCI=3.3V
<b>Power consumption (Panel+LSI)</b>	Sleeping Mode	-	-	0.005	mA	VCI=3.3V

## 13. INSPECTION

Standard acceptance/rejection criteria for TFT module according to document available [here](#).

## 14. RELIABILITY TEST

NO.	TEST ITEM	TEST CONDITION	NOTE
1	High Temperature Storage	80°C/120 hours	A,B,C,D,E
2	Low Temperature Storage	-30°C/120 hours	
3	High Temperature Operating	70 °C /120 hours	
4	Low Temperature Operating	-20°C/120 hours	
5	High Temperature and High Humidity	+60°C , 90%RH, 120hrs	
6	Thermal Cycling Test (No operation)	-20°C /30 min ~ +70°C /30 min for a total 5 cycles, Start with cold temperature and end with high temperature.	A,B,C,D,E
7	Vibration Test	Sweep:10Hz~55Hz~10Hz 2G 2 hours for each direction of X. Y. Z. (6 hours for total)	A,B,C,D,E
8	Package Vibration Test	Random Vibration : 0.015G*G/Hz from 5-200HZ, -6dB/Octave from 200-500HZ 2 hours for each direction of X. Y. Z. (6 hours for total)	A,B,C,D,E
8	Package Drop Test	Height: 60 cm 1 corner, 3 edges, 6 surfaces	A,B,C,D,E
9	ESD	Contact=+/-4KV, Air=+/-8KV,(R=330R,C=150pF), 1 sec,9point,10times/point;	A,B,C,D,E

### Notes

- A. LCM each function is OK.
- B. LCM appearance inspection without abnormalities (Including scratch, damage, corrosion and serious deformation)
- C. LCM brightness above the Min. value of Spec.
- D. Luminance uniformity above the Min. value of Spec.
- E. Color chromaticity within tolerance range.



## 15. LEGAL INFORMATION

CE marking is usually obligatory only for a complete end product. Riverdi display modules are semi-finished goods which are used as inputs to become part of the finished products.

Therefore, Riverdi display modules are not CE marked.

This is not a standalone product. It was designed as an electronic component. It needs integration with a whole system to be fully functional.

Riverdi grants the guarantee for the proper operation of the goods for a period of 12 months from the date of possession of the goods. If in a consequence of this guaranteed execution the customer has received the defects-free item as replacement for the defective item, the effectiveness period of this guarantee shall start anew from the moment the customer receives the defects-free item.

Information about device is the property of Riverdi and may be the subject of patents pending or granted. It is not allowed to copy or disclosed this document without prior written permission.

Riverdi endeavors to ensure that all contained information in this document is correct but does not accept liability for any error or omission. Riverdi products are in developing process and published information may be not up to date. Riverdi reserves the right to update and makes changes to Specifications or written material without prior notice at any time. It is important to check the current position with Riverdi.

Images and graphics used in this document are only for illustrative the purpose. All images and graphics are possible to be displayed on the range products of Riverdi, however the quality may vary. Riverdi is no liable to the buyer or to any third party for any indirect, incidental, special, consequential, punitive, or exemplary damages (including without limitation lost profits, lost savings, or loss of business opportunity) relating to any product, service provided or to be provided by Riverdi, or the use or inability to use the same, even if Riverdi has been advised of the possibility of such damages.

Riverdi products are not fault tolerant nor designed, manufactured or intended for use or resale as on line control equipment in hazardous environments requiring fail-safe performance, such as in the operation of nuclear facilities, aircraft navigation or communication systems, air traffic control, direct life support machines or weapons systems in which the failure of the product could lead directly to death, personal injury or severe physical or environmental damage ('High-Risk Activities'). Riverdi and its suppliers specifically disclaim any expressed or implied warranty of fitness for High-Risk Activities. Using Riverdi products and devices in 'High-Risk Activities' and in any other application is entirely at the buyer's risk, and the buyer agrees to defend, indemnify and hold harmless Riverdi from all damages, claims or expenses resulting from such use. No licenses are conveyed, implicitly or otherwise, under any Riverdi intellectual property rights.

## 16. CONTACT

### Your Success is Our Priority

Stuck on a technical challenge? Need expert guidance?  
Our dedicated support team is just a message away.

Contact us at

[contact@riverdi.com](mailto:contact@riverdi.com)

We're here to ensure your project's success, every step of the way!